

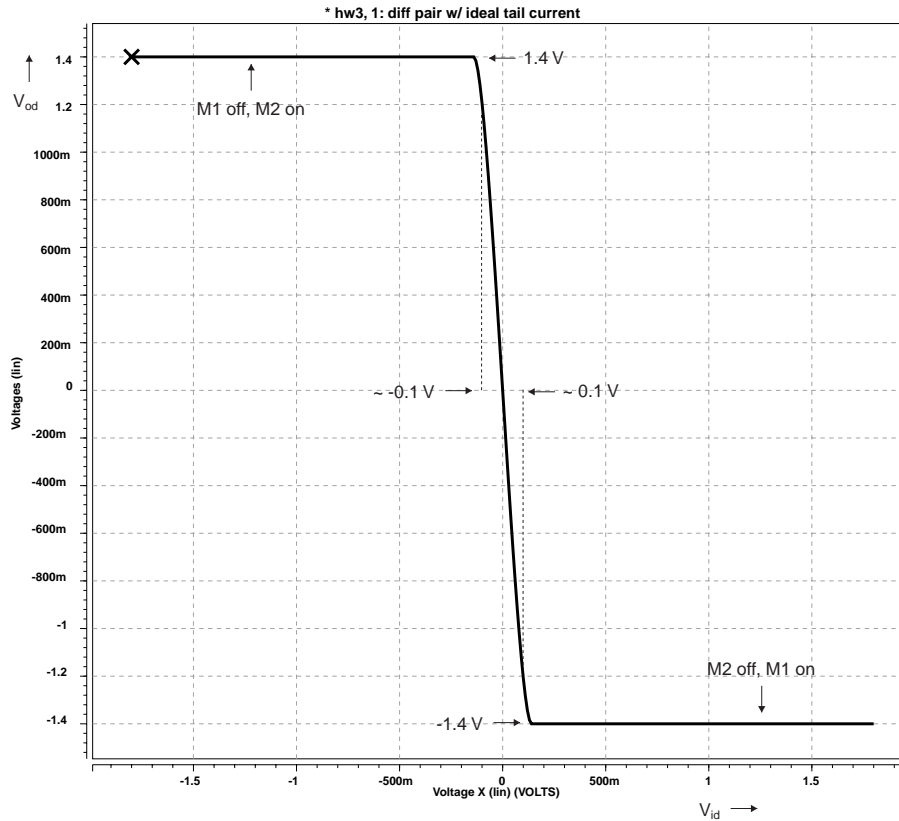

b) Plot  $V_{od}=(V_{o1}-V_{o2})$  vs.  $V_{id}$ , with  $V_{ic}=0.9$  V over the range  $-1.8 < V_{id} < +1.8$  V.



The slope around  $V_{id}=0$  V is  $A_{dm} = -g_m R_{out} \approx -g_m R_D = -\left(\sqrt{2k' \frac{W}{L} I_{DS}}\right) R_D = -14$ .

The curves limit when all of the current is switched to one side of the differential pair. When this happens, the differential voltage is  $I_{SS} R_D = 1.4$  V .

The voltage that this occurs at can be approximated by  $\Delta V_{id} = \frac{I_{SS} R_D}{g_m R_D} = 0.1$  V .

It is also correct to find the exact point where one transistor turns off and the other takes all of the current. This occurs for  $\Delta V_{id} = \sqrt{\frac{2I_{SS}}{k' \frac{W}{L}}} = 0.14$  V .

c) Plot  $V_{oc}=(V_{o1}+V_{o2})/2$  vs.  $V_{ic}$ , with  $V_{id}=0$  V over the range  $0 < V_{ic} < +1.8$  V.

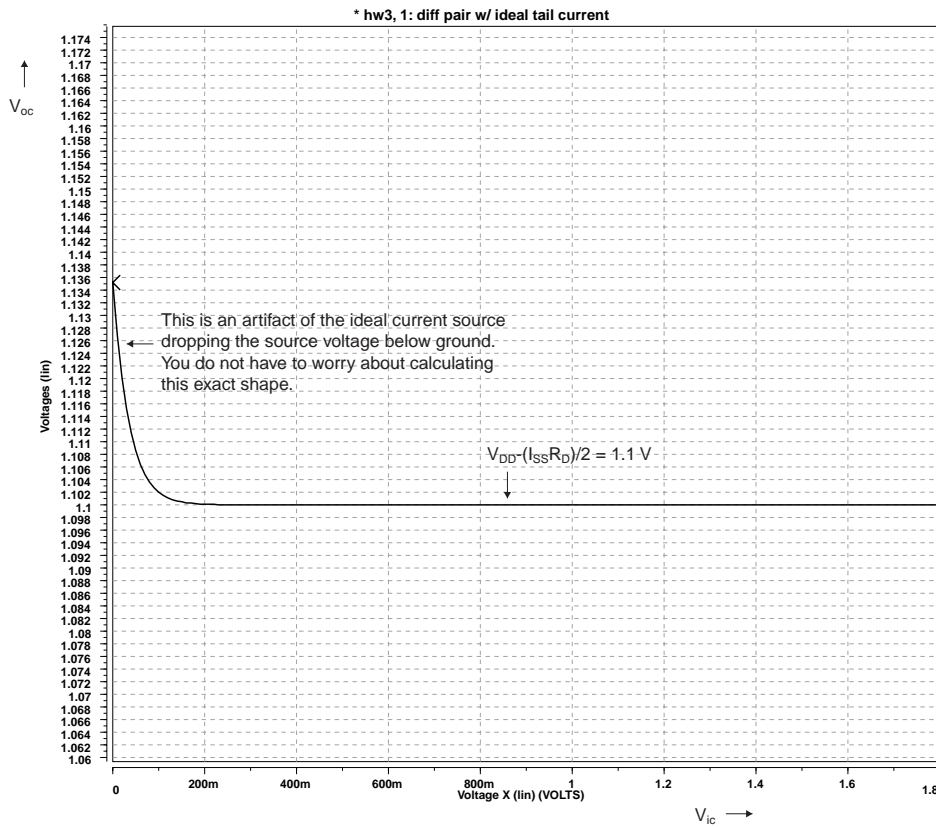

There are no breakpoints in this curve. The strange behavior near  $V_{oc}=0$  V is only an artifact of the ideal current source pulling the source voltage below ground. When  $V_S < 0$  V, the source-bulk junction diode begins to be forward biased and starts to conduct current. This will not happen with any real implementation, and you do not have to worry about calculating this.

d) Calculate  $A_{dm}$  with  $V_{ic}=0.9$  V,  $V_{id}=0$  V. Over what range of  $V_{id}$  will the gain remain high? Why does the gain drop off?

$$\begin{aligned}
 A_{dm} &= -g_m (R_D \parallel r_o) \approx -g_m R_D \\
 &= -\sqrt{2(140 \mu\text{A}/\text{V}^2)(10)(70 \mu\text{A})(100 \text{k})} \\
 &= -14
 \end{aligned}$$

As calculated in part (b), the gain is high over the range of  $-0.1$  V  $< V_{id} < 0.1$  V. The gain drops off because one of the transistors goes into cutoff.

e) Calculate  $A_{cm}$  with  $V_{ic}=0.9$  V,  $V_{id}=0$  V.

$$A_{cm} \approx -\frac{g_m R_D}{1 + (1 + \chi)g_m(2r_o)}$$

For an ideal current source, the output resistance is  $r_o = \infty$ , and therefore the common-mode gain is,  $A_{cm} = 0$ .

f) Calculate  $R_{od}$  with  $V_{ic}=0.9$  V,  $V_{id}=0$  V.

$$\begin{aligned} R_{od} &= 2(R_D \parallel r_o) = 2(100 \text{ k} \parallel 1.4 \text{ M}) \\ &= 187 \text{ k}\Omega \end{aligned}$$

Verify (d)-(f) with SPICE using the .TF analysis option.

```

* hw4, 2: diff pair w/ ideal tail current

.model nch nmos level=1 tox=25 vto=0.5 kp=140e-6 lambda=0.1 gamma=0.5 phi=0.6

vdd    vdd 0 1.8

* set up common mode and differential inputs
vic    vic 0 0.9
vid    vid 0 0
e1     vi1 vic vid 0 0.5
e2     vi2 vic vid 0 -0.5

* set up to measure output common mode
e3     voc1 0 vo1 0 0.5
e4     voc  voc1 vo2 0 0.5
rcm    voc 0 1

rd1    vdd vo1 100k
rd2    vdd vo2 100k
m1     vo1 vi1 s 0 nch w=10u l=1u
m2     vo2 vi2 s 0 nch w=10u l=1u
iss    s 0 14u

.options post=2 nomod

.probe dc vod=v(vo1,vo2) voc=v(voc)

.op
.dc    vid -1.8 1.8 0.01
.dc    vic 0 1.8 0.01

.tf    v(vo1,vo2) vid

.alter
.tf    v(voc) vic

.end

**** mosfets

subckt
element 0:m1      0:m2
model   0:nch    0:nch
id      7.0000u  7.0000u
vgs     665.4148m 665.4148m
vds    865.4147m 865.4147m           Vds
vth     569.4798m 569.4798m
vdsat   95.9349m  95.9349m

****      small-signal transfer characteristics

v(vo1,vo2)/vid           = -13.7100           Adm
input resistance at      vid           = 1.000e+20
output resistance at v(vo1,vo2) = 187.8949k           Rod

****      small-signal transfer characteristics

v(voc)/vic              = -79.0254n           Acm
input resistance at      vic           = 1.000e+20
output resistance at v(voc)           = 0.

```

The schematic for the circuit used in Problem is:

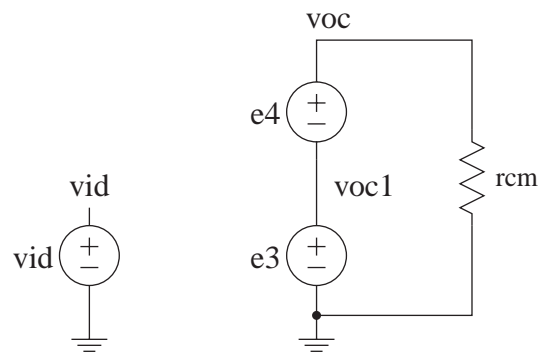
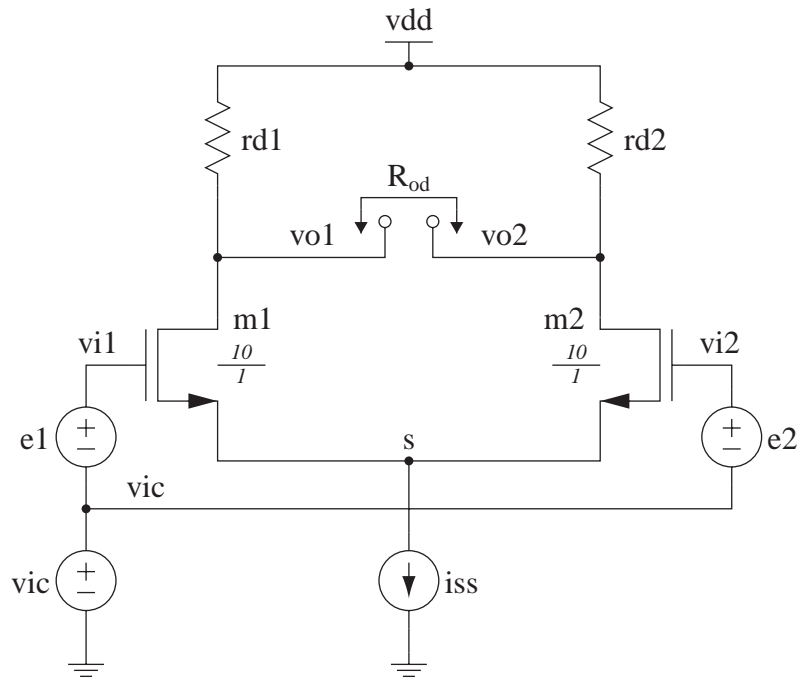

### PROBLEM SET #3

3). Replace the  $I_{SS}$  current source with a resistor which results in the same  $I_{DS}$  currents when  $V_{ic}=0.9\text{ V}$  and  $V_{id}=0\text{ V}$ .

a) To get the same current,  $R_{SS} = \frac{V_S}{I_{SS}} = \frac{0.231\text{ V}}{14\mu\text{A}} = 16.5\text{ k}\Omega$

Since the current and source voltage are the same,  $V_{DS}$  is also the same.

$$V_{DS} = 0.87\text{ V}$$

b) Plot  $V_{od}$  vs.  $V_{id}$  with  $V_{ic}=0.9\text{ V}$  over the range  $-1.8 < V_{id} < 1.8\text{ V}$ .

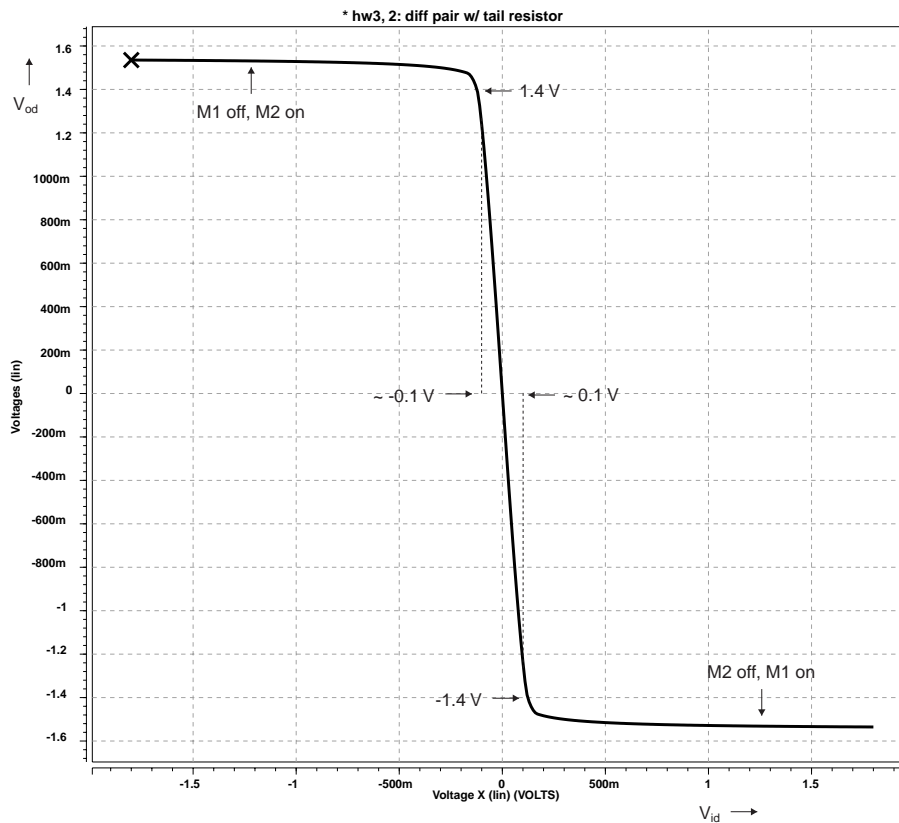

Differentially, this circuit behaves the same way as the circuit with an ideal current source. Therefore the breakpoints are the same as before:

$$\Delta V_{id} = \pm 0.1\text{ V}, \Delta V_{od} = \pm 1.4\text{ V}$$

When  $V_{id}$  is increased beyond this range, the current increases causing a small slope in the transfer function. This can be approximated by a flat line and the exact shape is not important.

c) Plot  $V_{oc}$  vs.  $V_{ic}$  with  $V_{id}=0$  V over the range  $0 < V_{ic} < +1.8$  V.

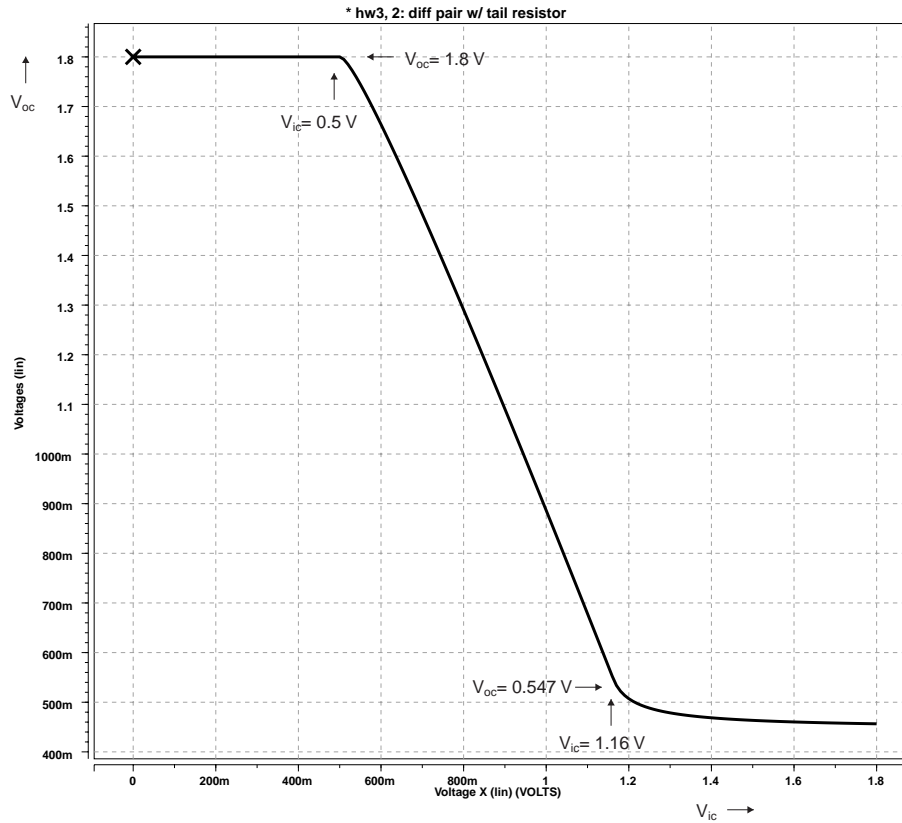

The equivalent half-circuit is

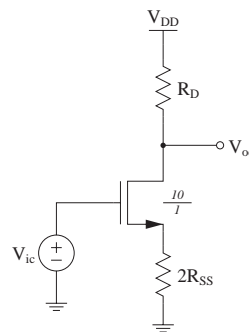

When  $V_{ic} < V_T$ , the transistor is operating in cutoff and the output is at  $V_{DD}=1.8$  V.

When  $V_{ic} > V_T$ , the transistor operates as a common-source with source-degeneration amplifier until it goes into triode. We need to find the point where this occurs. At the edge of saturation,

$$V_{DS} = V_{DSAT}$$

$$V_{DD} - I_{DS}(R_D + 2R_{SS}) = \sqrt{\frac{2I_{DS}}{k' \frac{W}{L}}}$$

$$(R_D + 2R_{SS})I_{DS} + \left( \sqrt{\frac{2}{k' \frac{W}{L}}} \right) \sqrt{I_{DS}} - V_{DD} = 0$$

Solving the quadratic equation,  $I_{DS} = 12.5 \mu\text{A}$ , and  $V_{DSAT} = 0.134 \text{ V}$ .

Therefore,  $V_S = I_{DS}(2R_{SS}) = 0.413 \text{ V}$ , and  $V_T = 0.616 \text{ V}$ . So, the transistor goes from saturation to triode at the point,

$$V_{ic} = V_S + V_T + V_{DSAT} = 1.16 \text{ V}$$

$$V_{oc} = V_S + V_{DSAT} = 0.547 \text{ V}$$

d) Since the differential half-circuit is exactly the same as with the ideal tail current source, this is the same as in (3d).

$$A_{dm} = -g_m(R_D \parallel r_o) = -14$$

and the gain is large over the range  $-0.1 \text{ V} < V_{id} < 0.1 \text{ V}$ . The gain drops off because one of the transistors goes into cutoff.

e) The common-mode gain is slightly different due to the source resistor.

$$A_{cm} = -\frac{g_m R_D}{1 + (1 + \chi)g_m(2R_{SS})} = -2$$

where

$$g_m = 140 \mu\text{S}$$

$$\chi = \frac{\gamma}{2(2\phi + V_{SB})^{1/2}} = 0.274$$

f) The differential output resistance is the same as in (4f),

$$R_{od} = 2(R_D \parallel r_o) = 187 \text{ k}\Omega$$

```

* hw4, 3: diff pair w/ tail resistor

.model nch nmos level=1 tox=25 vto=0.5 kp=140e-6 lambda=0.1 gamma=0.5 phi=0.6

vdd    vdd 0 1.8

* set up common mode and differential inputs
vic    vic 0 0.9
vid    vid 0 0
e1     vi1 vic vid 0 0.5
e2     vi2 vic vid 0 -0.5

* set up to measure output common mode
e3     voc1 0 vo1 0 0.5
e4     voc  voc1 vo2 0 0.5
rcm    voc 0 1

rd1    vdd vo1 100k
rd2    vdd vo2 100k
m1     vo1 vi1 s 0 nch w=10u l=1u
m2     vo2 vi2 s 0 nch w=10u l=1u
rss    s 0 16.5k

.options post=2 nomod

.probe dc vod=v(vo1,vo2) voc=v(voc)

.op
.dc    vid -1.8 1.8 0.01
.dc    vic 0 1.8 0.01

.tf    v(vo1,vo2) vid

.alter
.tf    v(voc) vic

.end

**** mosfets

subckt
element 0:m1      0:m2
model   0:nch    0:nch
id      7.0927u  7.0927u
vgs     665.9422m 665.9422m
vds    856.6759m 856.6759m           Vds
vth     569.3355m 569.3355m
vdsat   96.6067m  96.6067m

****      small-signal transfer characteristics

v(vo1,vo2)/vid           = -13.7831           Adm
input resistance at      vid           = 1.000e+20
output resistance at v(vo1,vo2) = 187.7352k           Rod

****      small-signal transfer characteristics

v(voc)/vic              = -2.0228           Acm
input resistance at      vic           = 1.000e+20
output resistance at v(voc)           = 0.

```

The schematic for the circuit used is:

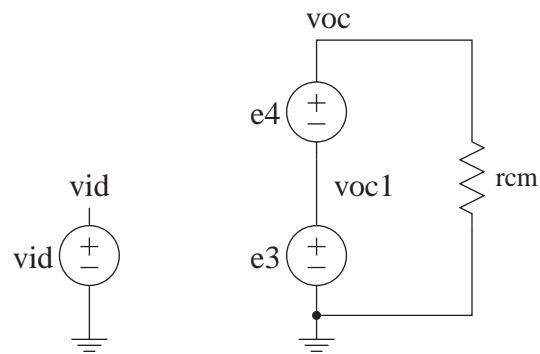
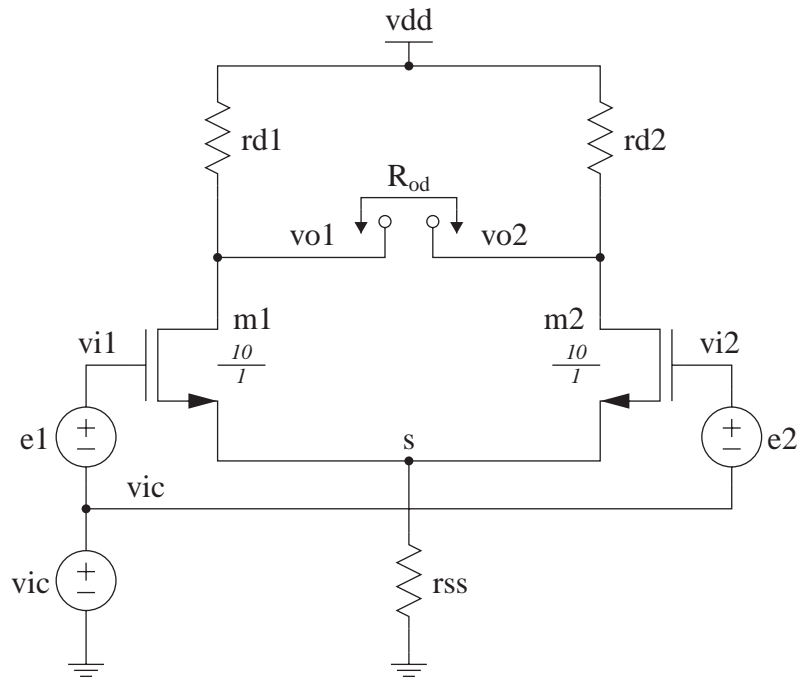

1.  $I_{D1} = I_{D2} \Rightarrow V_{in} = 1.254 \Rightarrow I_D = 2.316 \text{ mA}$

$$g_{m1} = \mu_n C_{ox} \left(\frac{W}{L}\right)_1 (V_{GS1} - V_{THN}) = 1.34 \times 10^{-4} \times 100 \times (1.254 - 0.7) = 7.43 \text{ mS}$$

$$g_{m2} = \mu_p C_{ox} \left(\frac{W}{L}\right)_2 (V_{GS2} - V_{THP}) = 3.84 \times 10^{-5} \times 100 \times (3 - 1.254 - 0.8) = 3.63 \text{ mS}$$

$$r_{o1} = \frac{1}{\lambda_1 I_1} = 4.317 \text{ k}$$

$$r_{o2} = \frac{1}{\lambda_2 I_2} = 2.159 \text{ k}$$

(a)

a)  $A_V = -(g_{m1} + g_{m2})(r_{o1} || r_{o2}) = 15.91$

$$R_{out} = r_{o1} || r_{o2} = 1439 \Omega$$

b)  $v_g = v_{in} \times \frac{R_2}{R_1 + R_2} + v_o \times \frac{R_1}{R_1 + R_2}$

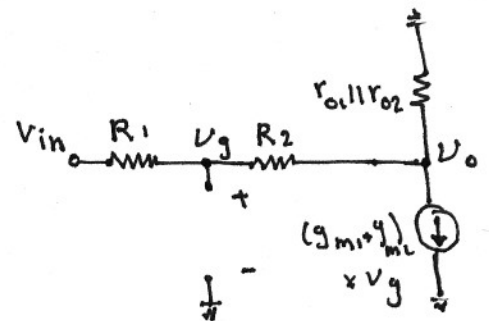

$$\frac{v_o - v_{in}}{R_1 + R_2} + \frac{v_o}{r_{o1} || r_{o2}} + (g_{m1} + g_{m2}) \left[ v_{in} \frac{R_2}{R_1 + R_2} + v_o \frac{R_1}{R_1 + R_2} \right] = 0$$

$$\Rightarrow A_V = \frac{v_o}{v_{in}} = - \frac{(g_{m1} + g_{m2}) R_2}{1 + (g_{m1} + g_{m2}) R_1 + \frac{R_1 + R_2}{r_{o1} || r_{o2}}} = 5.57$$

to calculate  $R_{out}$ :

$$v_{in} = 0$$

$$i_o = \frac{v_o}{r_{o1} || r_{o2}} + \frac{v_o}{R_1 + R_2} + (g_{m1} + g_{m2}) \times \left[ v_o \times \frac{R_1}{R_1 + R_2} \right]$$

$$= v_o \left[ \frac{1}{r_{o1} || r_{o2}} + \frac{1 + (g_{m1} + g_{m2}) R_1}{R_1 + R_2} \right]$$

$$\Rightarrow R_{out} = \frac{v_o}{i_o} = 557 \Omega$$

(b) We figure out sensitivity for (b),

(a) is a special case where

$$R_1 = 0 \quad R_2 = \infty$$

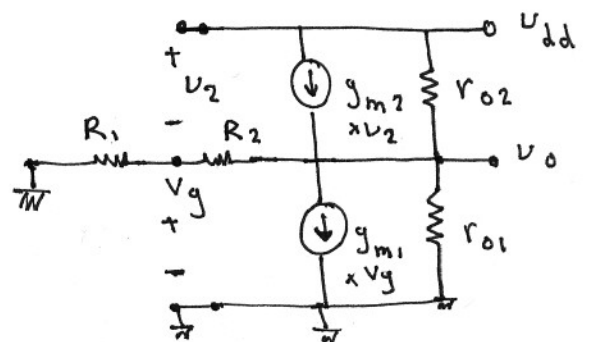

$$V_g = V_o \times \frac{R_1}{R_1 + R_2}$$

$$\frac{V_o - V_{dd}}{r_{o2}} + \frac{V_o}{r_{o1}} + \frac{V_o}{R_1 + R_2} + g_{m1} \times V_o \times \frac{R_1}{R_1 + R_2}$$

$$+ g_{m2} \left( V_o \times \frac{R_1}{R_1 + R_2} - V_{dd} \right) = 0$$

$$\Rightarrow \frac{g_{m2} + \frac{1}{r_{o2}}}{\frac{1}{r_{o1}} + \frac{1}{r_{o2}} + \frac{1}{R_1 + R_2} + \frac{(g_{m1} + g_{m2}) R_1}{R_1 + R_2}} = 2.28 = A_v$$

if  $R_1 = 0$  and  $R_2 = \infty$

$$A_v = \left[ g_{m2} + \frac{1}{r_{o2}} \right] (r_{o1} \parallel r_{o2}) = (3.63 + 0.46) \times 1.439$$

$$= 5.84$$