

# In-class Exercise 10

(PAR 14)

- What is the equation represented by the following BDD?

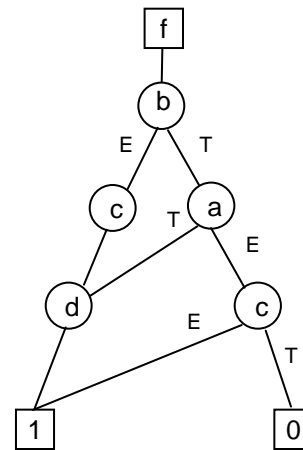

- Create a BDD to implement  $F(a, b, c, d) = abcd + c'd + a'd'$ 
  - Using the variable ordering  $a \leq b \leq c \leq d$

# In-class Exercise 10

(PAR 14)

- What is the equation represented by the following BDD?

$$F = ab + a'bc' + b'$$

$$\begin{aligned} F &= cF_c + c'F_{c'} \\ &= c(1) + c'(1) \\ &= 1 \end{aligned}$$

$$\begin{aligned} F &= dF_d + d'F_{d'} \\ &= d(1) + d'(1) \\ &= d + d' = 1 \end{aligned}$$

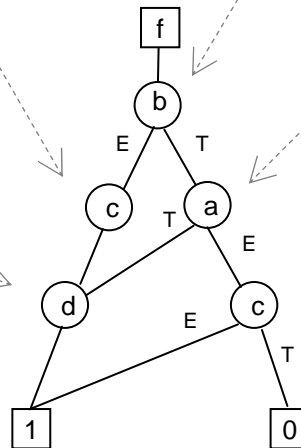

$$\begin{aligned} F &= bF_b + b'F_{b'} \\ &= b(a + a'c') + b'(1) \\ &= ab + a'bc' + b' \end{aligned}$$

$$\begin{aligned} F &= aF_a + a'F_{a'} \\ &= a(1) + a'(c') \\ &= a + a'c' \end{aligned}$$

$$\begin{aligned} F &= cF_c + c'F_{c'} \\ &= c(0) + c'(1) \\ &= c' \end{aligned}$$

$x \cdot 1 = x$	$x + 1 = 1$
$x \cdot 0 = 0$	$x + 0 = x$

# In-class Exercise 10

(PAR 14)

- Create a BDD to implement  $F(a, b, c, d) = abcd + c'd + a'd'$ 
  - Using the variable ordering  $a \leq b \leq c \leq d$

$$F_a = bcd + c'd$$

$$F_{a'} = c'd + d'$$

$$F_{ab} = cd + c'd$$

$$F_{a'b} = c'd + d'$$

$$F_{ab'} = c'd$$

$$F_{a'b'} = c'd + d'$$

$$F_{abc} = d$$

$$F_{a'bc} = d'$$

$$F_{abc'} = d$$

$$F_{a'bc'} = d + d' = 1$$

$$F_{ab'c'} = 0$$

$$F_{a'b'c'} = d'$$

$$F_{ab'c} = d$$

$$F_{a'b'c} = d + d' = 1$$

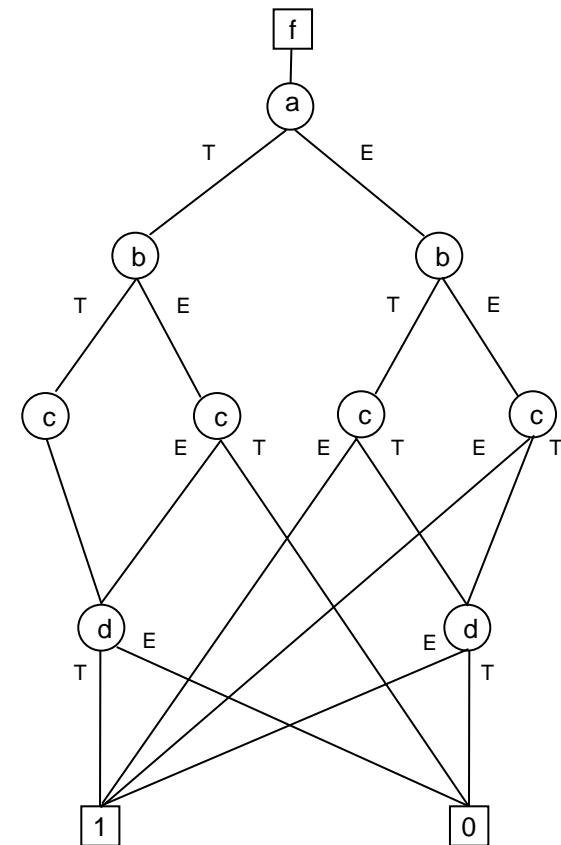

*When you get to a constant or single term, you can stop*

*These BDDs are easy to construct*

# In-class Exercise 10

(PAR 14)

- What if we need to make sure it was a ROBDD?

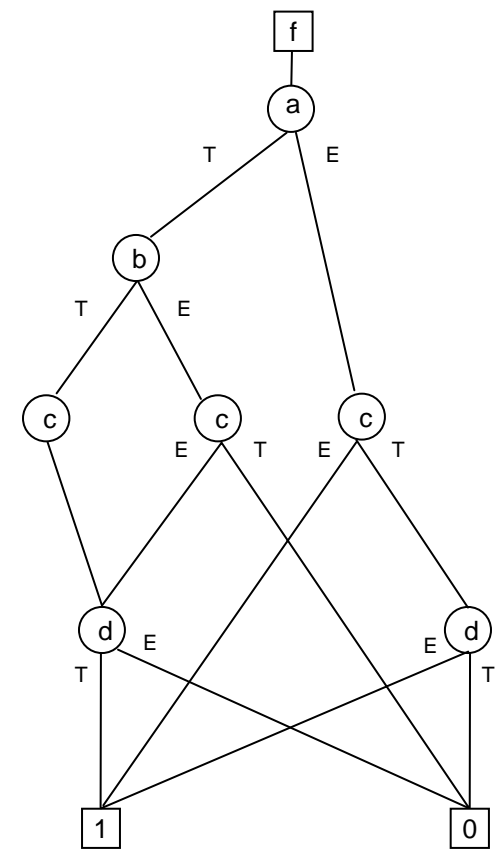
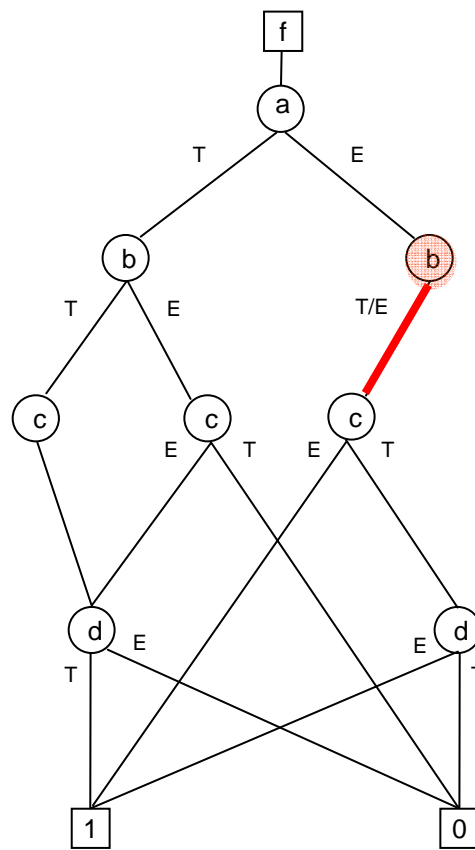
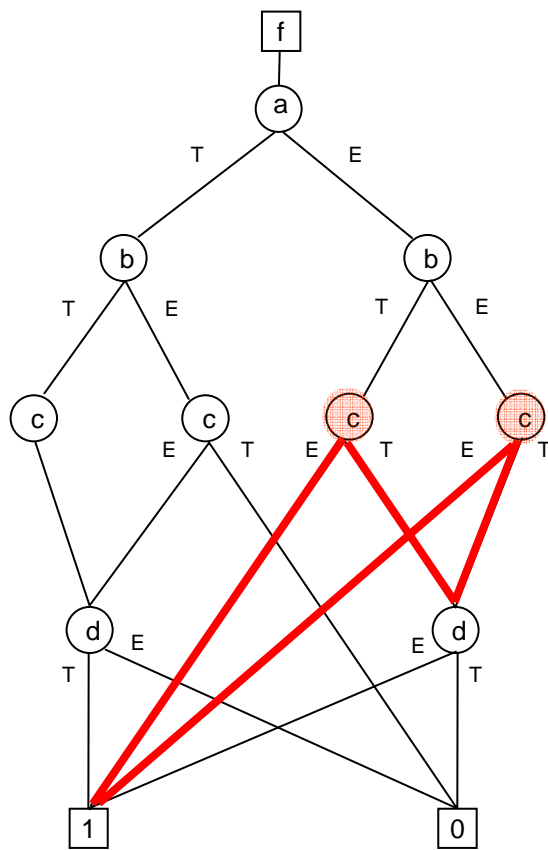

# In-class Exercise 10

(PAR 14)

- What if we need to make sure it was a ROBDD?

