

PRACTICE PROBLEMS 8
Lecture 11 - 12

1. Fill in the following table

$X \cdot 1 =$	$X + 1 =$
$X \cdot 0 =$	$X + 0 =$

2. What does canonical mean? Provide two canonical representations of $F = a + b'c + bc'$.

3. Using only muxes, build a circuit to perform

- a. $F = A \text{ NAND } B$
- b. $F = A + B + C$

4. Which of the following circuits are functionally equivalent to $F = a \text{ xor } b$?

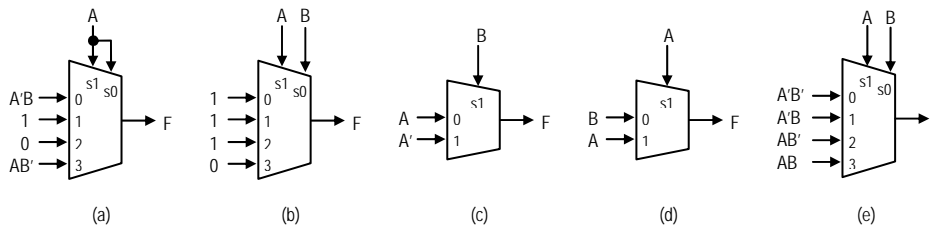

5. Using the Shannon Expansion Theorem, expand $F(a, b, c) = ac + ab'c + b$, with respect to

- a. Variable a
- b. Variable b
- c. Variable c

6. Convert $F = a \text{ xor } b \text{ xor } c$ into a BDD, using the variable ordering $a \leq b \leq c$.

7. Convert $F(a, b, c, d) = a + bc'd + a'bcd + b'd$ to its corresponding BDD representation, using the variable ordering $a < b < c < d$. Be sure to reduce the BDD if possible.

8. Convert $F(a, b, c, d) = ab + a'bc' + a'b'c + d$ to its corresponding BDD representation. Use the variable ordering $a \leq b \leq c \leq d$.

9. Given $F = abc + bc'd + b'd$, which of the following variable orderings is "best" to implement a ROBDD?

- a. Variable ordering $d < c < b < a$
- b. Variable ordering $b < c < a < d$

10. Determine the equation represented by the BDD below.

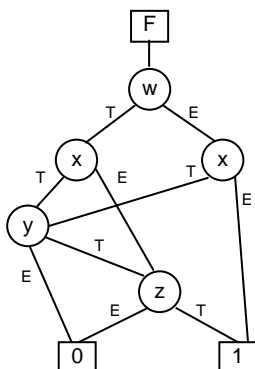

11. Determine the equation represented by the BDD below.

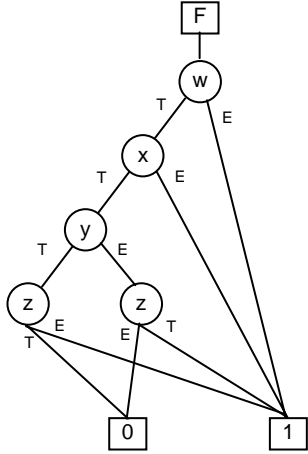

12. Convert the following BDD into an ROBDD, using the variable ordering $A < B < C$.

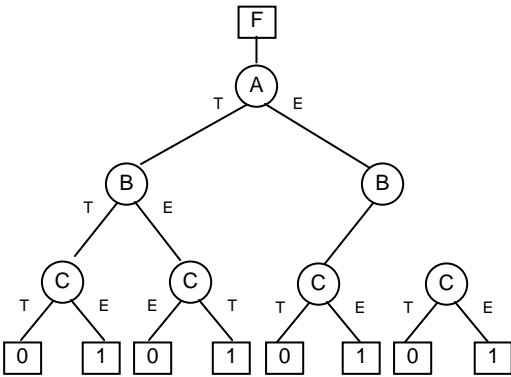

13. Convert the following BDD into an ROBDD, using the variable ordering $C < A < B$.

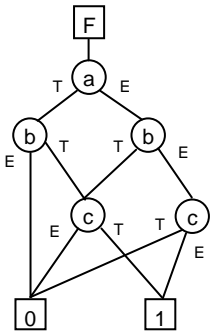

14. Let $F=ad$, $G=c+d$, $H=ab'$, and $I=FG+F'H$

- Build a BDD for F , G , and H . Then composed the BDD for I by iteratively connecting the previously created BDDs.
- Using the ITE algorithm create a BDD for I .
- What are the benefits of using the ITE algorithm?

15. Let $F=ab+c$, $G=c'd$, $H=a'b'+ab$, and $I=FG+F'H$. Use the ITE algorithm to create a BDD for I. Be sure to show the corresponding steps of the ITE algorithm and the resulting BDD. Use the variable ordering $a < c < b < d$.
16. Let $F=abc + cd + a'b'c'$. Use the ITE algorithm to create the corresponding BDD for F. Be sure to show the corresponding steps of the ITE algorithm and the resulting BDD. Use the variable ordering $c < a < d < b$.

17. Encoding the FSM below using the encoding techniques specified below
- Minimum bit-width binary encoding
 - One-hot encoding
 - Output encoding.

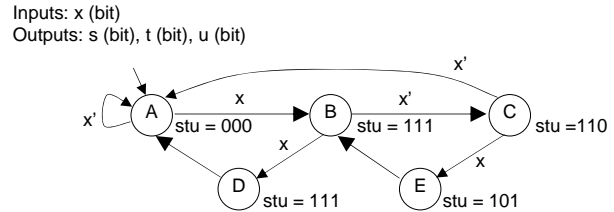

18. Reduce the number of states for the FSM below by eliminating redundant states by using an implication table. Draw the resulting FSM.

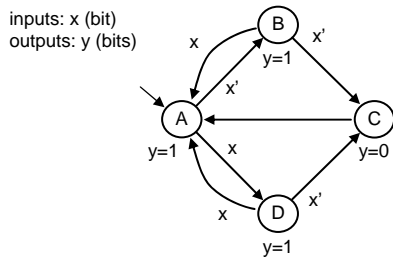

19. Reduce the number of states for the FSM below by eliminating redundant states by using an implication table. Draw the resulting FSM.

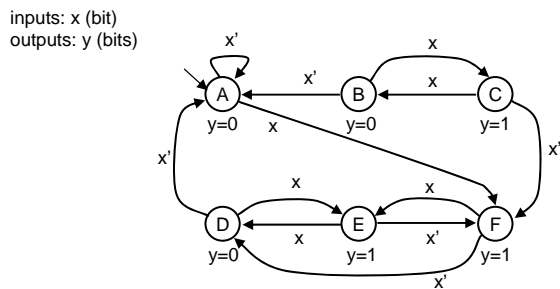

20. Reduce the number of states for the FSM below by eliminating redundant states by using an implication table. Draw the resulting FSM.

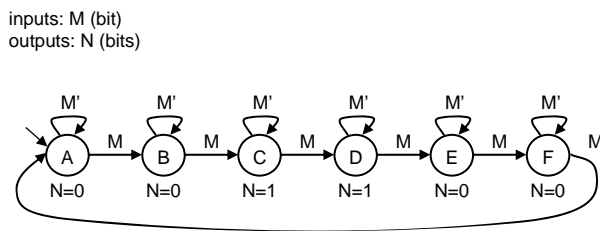

21. Minimize the following state table using the partitioning approach. Show the corresponding partitions, you do not need to show the minimized FSM.

Inputs		Outputs	
Current State	a	Next State	f
P	0	S	1
P	1	T	1
Q	0	R	1
Q	1	T	1
R	0	T	0
R	1	R	0
S	0	T	0
S	1	R	0
T	0	S	1
T	1	Q	1
U	0	R	0
U	1	T	0

22. Using the FSM provided

- Derive the equivalent state table
- Utilizing the state table minimize the FSM (i.e. partitioning approach), be sure to show each step
- Draw the minimized FSM

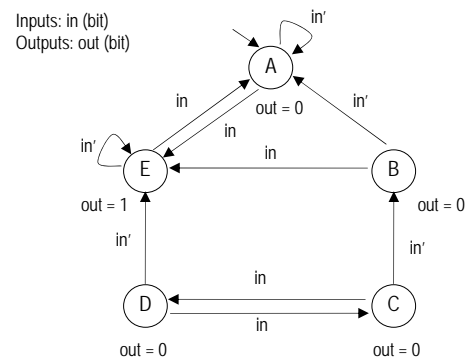

23. Which of the following yields the optimal state encoding assignment

- Minimum bit width binary encoding (A=00, B=01, C=10)
- Modified minimum bit width binary encoding (A=00, B=01, C=11)
- One-hot
- Output encoding

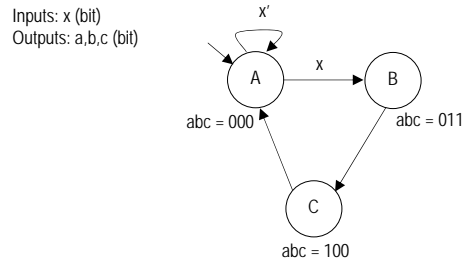

ECE 574A Only

24. Given $F(a, b, c) = ab + a'bc' + b'c'$, determine the optimal variable ordering.

25. Describe how the optimal variable ordering can be found. What is the complexity of your method?